



Quantum
SERIES EXCAVATORS®

2800
SPECIFICATIONS

45,300 lbs. (20 600 kg) Operating Weight

Link-Belt
EXCAVATORS
SCRAPMASTER | LOGMASTER

2800 Quantum Specifications

ENGINE

Isuzu 6BG1T turbocharged, water cooled, 4-cycle diesel, 6 cylinder, 396 CID (6 494 cc), 4.13" (105 mm) bore x 4.92" (125 mm) stroke.

SAE net horsepower 128 HP (95.5 kW) @ 1,900 rpm
Maximum torque 342 ft.-lbs. (47.3 kg-m or 464 N-m) @ 1,600 rpm
Starter Electric, 24V, 4.5 kW
Alternator 40 amp
Air cleaner Double element
Governor Variable speed, mechanical

HYDRAULIC SYSTEM

Two variable displacement axial piston pumps and one gear pump for pilot controls, with Link-Belt Intelligent Quantum (IQ) Control. Link-Belt IQ Control includes: four selectable working modes, presettable allied attachment work mode, free swing, one-touch decelerator, auto idling system, power up mode, selectable cushion attachment control, and three safety lockout switches including gate lock.

Hydraulic Pumps

Two variable volume piston pumps provide power for attachment, swing and travel.

Maximum flow 2 x 52 gpm (2 x 196 l/min)
Pilot pump max. flow 5.3 gpm (20 l/min)

Relief Valve Settings

Boom/arm/bucket 4,550 psi (320 kg/cm²)
in Power Up Mode 4,980 psi (350 kg/cm²)
Swing circuit 4,050 psi (285 kg/cm²)
Travel circuit 4,980 psi (350 kg/cm²)

Hydraulic Cylinders – number of cylinders – bore x rod x stroke.

Boom 2 – 4.9" x 3.3" x 49.6" (125 mm x 85 mm x 1 259 mm)
Arm 1 – 5.3" x 3.9" x 62.2" (135 mm x 100 mm x 1 580 mm)
Bucket 1 – 4.7" x 3.1" x 39.8" (120 mm x 80 mm x 1 012 mm)

Oil Filtration

Nephron filter 1 micron
Return, pilot, drain filter 10 micron
Suction filter 105 micron

Control Valve One 4-spool valve and one 5-spool valve with auxiliary spool.

CAB AND CONTROLS

Cab mounted on 6 fluid filled mountings. Features include a safety glass front window and LEXAN® MARGARD™ rear and side windows, reclining/sliding cloth upholstered suspension seat with headrest and armrests, heater, oscillating fan, AM/FM radio, cigarette lighter, pop-up skylight window, and intermittent wiper with washer. Front window slides upward for storage and the lower front window is removable. Control levers are located in 4-position tilting control consoles. Reliable soft-touch switches. Easy-to-read illuminated LCD service monitor keeps operator in touch with critical machine functions.

SWING

Planetary reduction powered by axial piston motor. Internal ring gear with grease cavity for swing pinion. Swing bearing is single-row shear type ball bearing. Swing cushion valve and dual stage relief valves for smooth swing deceleration and stops. Mechanical disc swing brake.

Swing speed 0 – 11.9 rpm
Tail swing 9' 1" (2.80 m)
Swing torque 44,800 ft.-lbs. (6 194 kg-m)

UNDERCARRIAGE

X-style carbody is integrally welded for strength and durability. Grease cylinder track adjusters with shock absorbing springs. LC undercarriage with lubricated rollers and idlers. Triple grouser track shoes.

Carrier rollers 2 per side
Track rollers 8 per side
Shoes 49 per side
Shoe width 31.5" (800 mm)
Ground pressure 4.69 psi (.33 kg/cm²)

Alternating inner and outer flanged rollers are used to assure proper track rail to roller engagement.

TRAVEL SYSTEM

Three-speed independent hydrostatic travel with compact axial piston motors for increased performance. Hydraulic motor powered output shaft coupled to a planetary reduction unit and track sprocket. All hydraulic components mounted within the width of side frame. Travel speeds selected by floor mounted foot switch.

Automatic Downshift: When operating in difficult travel conditions or on slopes, travel motor automatically downshifts from high speed to mid-range speed for increased tractive effort. Machine will automatically return to high speed after traveling out of difficult terrain.

Max. travel speed 1.4/2.1/3.4 mph (2.3/3.3/ 5.5 km/h)
Traction force 41,230 lbs. (18 700 kg)
Gradeability 70%

Spring applied, hydraulically released disc parking brake built into each motor. Each travel motor equipped with counterbalance valve to prevent overspeeding down an incline and dual stage reliefs for smooth starts and stops.

LUBRICANT & COOLANT CAPACITY

Hydraulic tank 32 gal. (120 liters)
Hydraulic system 53 gal. (200 liters)
Final drive (per side) 1.3 gal. (4.7 liters)
Swing drive 1.3 gal. (5 liters)
Engine 5.2 gal. (19.5 liters)
Fuel tank 82 gal. (310 liters)
Cooling system 6.7 gal. (25.5 liters)

ATTACHMENT

Available Arms	Digging Force
• 7' 11" (2.40 m) in Power Up Mode – 26,680 lbs. (12 100 kg)	24,480 lbs. (11 100 kg)
• 9' 10" (3.00 m) in Power Up Mode – 22,270 lbs. (10 100 kg)	20,290 lbs. (9 200 kg)
Bucket digging force in Power Up Mode – 28,000 lbs. (12 700 kg)	25,580 lbs. (11 600 kg)

OPERATING WEIGHT

Working weight with 31.5" (800 mm) shoes, 9' 10" (3.00 m) arm and 1,407 lb. (638 kg) bucket 45,300 lbs. (20 600 kg)

STANDARD EQUIPMENT

- Isuzu 6BG1T diesel engine
- 40 amp alternator
- Double element air filter
- 24-volt starting system, battery lighting system, sealed heavy duty electrical connectors
- Intelligent Quantum (IQ) Control with manual backup system
- Self-diagnostic system
- Nephron filtration system
- Swing-out oil cooler
- Four selectable working modes
- One-touch decelerator
- Auto idling system
- Auto engine warm up
- Power up mode
- Integral cylinder cushioning
- Cushion attachment control
- Boom and arm holding valves
- Free swing control
- 3-speed hydrostatic travel
- Travel alarm
- Spare accessory valve
- Sliding/reclining, suspension cloth upholstered seat with 4-position tilting consoles and sliding platform
- Illuminated LCD service monitor
- Heater, fan, seat belt, horn, dome light, AM/FM radio, digital clock, floor mat, cigarette lighter
- Safety glass front window with automatic lock and intermittent windshield wiper and washer, large LEXAN® rear/side windows
- Vandalism locks/guarding
- Hand grab rails both sides
- Upper and lower undercovers
- LC undercarriage
- 8,160 lb. (3 700 kg) counterweight
- Quick disconnects in hydraulic system for easy pressure checking

DIMENSIONS

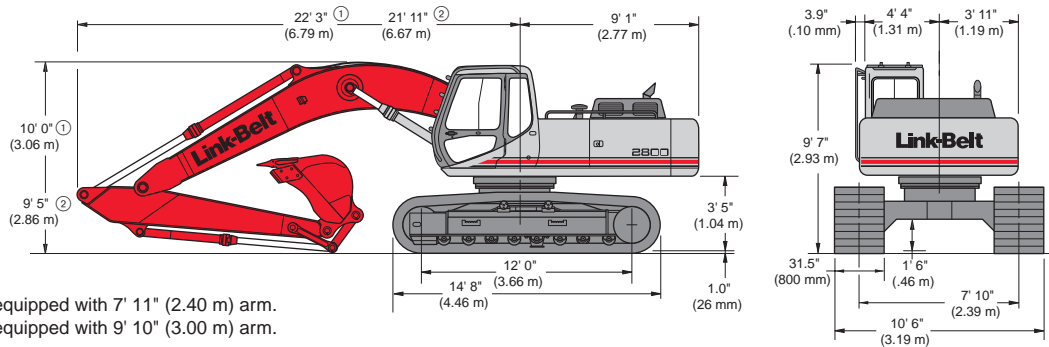

WORKING RANGES

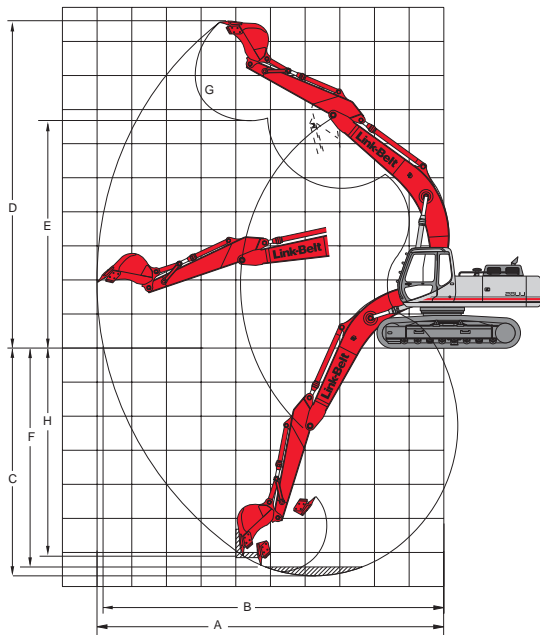

	18' 8" (5.70 m) Boom	
	7' 11" Arm 2.40 m	9' 10" Arm 3.00 m
A Max. digging radius	30' 11" 9.42 m	32' 8" 9.95 m
B Max. digging radius @ ground level	30' 4" 9.24 m	32' 1" 9.78 m
C Max. digging depth	20' 0" 6.10 m	21' 11" 6.69 m
D Max. digging height	30' 5" 9.26 m	31' 1" 9.47 m
E Max. dumping height	21' 2" 6.46 m	21' 11" 6.67 m
F Digging depth – 8' (2.44 m) level bottom	19' 4" 5.89 m	21' 5" 6.52 m
G Bucket wrist angle	183°	183°
H Max. vertical wall depth	17' 11" 5.47 m	19' 11" 6.07 m

BUCKETS

Bucket Type	Capacity	Width Outside Lip	Weight	# Teeth	Arm	
					7' 11" (2.40 m)	9' 10" (3.00 m)
ESCO STDP	.625 cu. yd. (.48 m ³)	24" (610 mm)	1,185 lb. (538 kg)	4	H	H
	.75 cu. yd. (.57 m ³)	30" (762 mm)	1,260 lb. (572 kg)	4	H	H
	1.0 cu. yd. (.76 m ³)	36" (914 mm)	1,469 lb. (666 kg)	5	H	H
	1.25 cu. yd. (.96 m ³)	42" (1 067 mm)	1,605 lb. (728 kg)	5	M	L
	1.5 cu. yd. (1.15 m ³)	48" (1 219 mm)	1,730 lb. (785 kg)	5	L	L
ESCO DITCH CLEANING	1.0 cu. yd. (.76 m ³)	60" (1 524 mm)	1,460 lb. (662 kg)	0	L	L
	1.12 cu. yd. (.86 m ³)	66" (1 676 mm)	1,560 lb. (708 kg)	0	L	L
ESCO HDP	.625 cu. yd. (.48 m ³)	24" (610 mm)	1,396 lb. (633 kg)	4	H	H
	.75 cu. yd. (.57 m ³)	30" (762 mm)	1,554 lb. (705 kg)	4	H	H
	1.0 cu. yd. (.76 m ³)	36" (914 mm)	1,747 lb. (792 kg)	5	H	H
	1.25 cu. yd. (.96 m ³)	42" (1 067 mm)	1,903 lb. (863 kg)	5	M	L
	1.5 cu. yd. (1.15 m ³)	48" (1 219 mm)	2,085 lb. (946 kg)	5	L	N/A
ESCO XDP	.50 cu. yd. (.38 m ³)	24" (610 mm)	1,771 lb. (803 kg)	3	H	H
	.75 cu. yd. (.57 m ³)	30" (762 mm)	2,011 lb. (912 kg)	4	H	H
	1.0 cu. yd. (.76 m ³)	36" (914 mm)	2,200 lb. (998 kg)	4	M	M
	1.12 cu. yd. (.86 m ³)	42" (1 067 mm)	2,439 lb. (1 106 kg)	5	M	L
	1.38 cu. yd. (1.06 m ³)	48" (1 219 mm)	2,624 lb. (1 190 kg)	5	L	N/A
ESCO HDC	.50 cu. yd. (.38 m ³)	24" (610 mm)	1,609 lb. (730 kg)	3	H	H
	.625 cu. yd. (.48 m ³)	30" (762 mm)	1,902 lb. (863 kg)	4	H	H
	.875 cu. yd. (.67 m ³)	39" (991 mm)	2,202 lb. (999 kg)	5	H	H

Approval Code For Arm/Bucket Combinations

H Heavy material
(up to 3,370 lbs./cu. yd.)

M Medium material
(up to 2,700 lbs./cu. yd.)

L Light material
(up to 2,020 lbs./cu. yd.)

N/A ... Not applicable

2800 Quantum Lifting Capacities

7' 11" (2.40 m) ARM EQUIPPED WITH 1,407 LB. (638 KG) BUCKET POWER UP MODE APPLIED											
Bucket Hook Height		Radius of Load									
		10' 0" (3.05 m)		15' 0" (4.57 m)		20' 0" (6.10 m)		25' 0" (7.62 m)		Capacity at Max. Reach	
		End	Side	End	Side	End	Side	End	Side	End	Side
+20' 0" (6.10 m)	lbs. kg					10,750* 4 876*	9,900 4 491			6,050* 2 744*	5,950 2 699
+15' 0" (4.57 m)	lbs. kg					11,750* 5 330*	9,650 4 377	9,350* 4 241	6,450 2 926	6,000* 2 722*	5,000 2 268
+10' 0" (3.05 m)	lbs. kg	26,100* 11 839*	26,100* 11 839*	17,000* 7 711*	14,450 6 555	13,550* 6 146*	9,150 4 150	10,000 4 536	6,300 2 858	6,150* 2 790*	4,600 2 087
+5' 0" (1.52 m)	lbs. kg			21,600* 9 798*	13,300 6 033	13,950 6 328	8,600 3 901	9,750 4 423	6,050 2 744	6,550* 2 971*	4,500 2 041
Ground Line	lbs. kg	16,850* 7 643*	16,850* 7 643*	21,800 9 888	12,650 5 738	13,550 6 146	8,250 3 742	9,550 4 332	5,850 2 654	7,200* 3 266*	4,700 2 132
-5' 0" (1.52 m)	lbs. kg	23,850* 10 818*	23,850* 10 818*	21,650 9 820	12,550 5 693	13,350 6 056	8,050 3 651	9,450 4 287	5,750 2 608	8,400* 3 810*	5,300 2 404
-10' 0" (3.05 m)	lbs. kg	32,650* 14 810*	25,650 11 635	21,850 9 911	12,700 5 761	13,450 6 101	8,150 3 697			10,600* 4 808*	6,850 3 107
-15' 0" (4.57 m)	lbs. kg	26,700* 12 111*	25,900 11 748	18,700* 8 482*	13,150 5 965						

9' 10" (3.00 m) ARM EQUIPPED WITH 1,407 LB. (638 KG) BUCKET POWER UP MODE APPLIED											
+20' 0" (6.10 m)	lbs. kg									4,000* 1 814*	4,000* 1 814*
+15' 0" (4.57 m)	lbs. kg					10,550* 4 785*	9,850 4 468	9,100* 4 128*	6,650 3 016	4,000* 1 814*	4,000* 1 814*
+10' 0" (3.05 m)	lbs. kg	22,450* 10 183*	22,450* 10 183*	15,150* 6 872*	14,850 6 736	12,500* 5 670*	9,350 4 241	10,150 4 604	6,400 2 903	4,100* 1 860*	4,100* 1 860*
+5' 0" (1.52 m)	lbs. kg	21,150* 9 594*	21,150* 9 594*	19,850* 9 004*	13,650 6 192	14,150 6 418	8,750 3 969	9,850 4 468	6,100 2 767	4,400* 1 996*	4,050 1 837
Ground Line	lbs. kg	18,200* 8 256*	18,200* 8 256*	22,000 9 979	12,800 5 806	13,650 6 192	8,300 3 765	9,550 4 332	5,850 2 654	4,900* 2 223*	4,200 1 905
-5' 0" (1.52 m)	lbs. kg	23,500* 10 660*	23,500* 10 660*	21,650 9 820	12,500 5 670	13,350 6 056	8,050 3 651	9,400 4 264	5,700 2 586	5,750* 2 608*	4,700 2 132
-10' 0" (3.05 m)	lbs. kg	31,550* 14 311*	25,350 11 499	21,700 9 843	12,550 5 693	13,300 6 033	8,050 3 651	9,450 4 287	5,750 2 608	7,250* 3 289*	5,800 2 631
-15' 0" (4.57 m)	lbs. kg	29,900* 13 563*	25,950 11 771	20,550* 9 321*	12,850 5 829	13,600 6 169	8,250 3 742			8,600* 3 901*	8,600* 3 901*

Notes: Excavator lifting capacities

- Lifting capacities shown should not be exceeded. Weight of all lifting accessories must be deducted from the above lifting capacities.
- Lifting capacities are based on machine standing on firm, uniform supporting surface. User must make allowances for job conditions such as soft or uneven ground.
- Lifting capacities shown do not exceed 75% of minimum tipping loads or 87% of hydraulic capacities. Capacities marked with an asterisk (*) are limited by hydraulic capacities.
- These capacities apply to machines having 4,980 psi (350 kg/cm²) boomhoist cylinder pressure.
- Least stable position is over the side.
- Lifting capacities are in compliance with SAE J1097 and ISO 10567. Operator should be fully acquainted with the Operator's Manual & Operating Safety Booklet, furnished by manufacturer before operating the machine.
- Capacities apply only to the machine as originally manufactured and normally equipped by LBX Company, LLC.

Intelligent Quantum (IQ) Control "The Smart System"

- **Four selectable working modes.** The mode selection system enables the operator to program the machine's speed to the job application:
H: Heavy Mode For heavy digging jobs, or any time you need extra power
S: Standard Mode For standard digging and loading operations
L: Light Mode For grading and other jobs where safety and precision are more important than power
F: Fine Mode For lifting and operations that need fingertip accuracy
- **Preselectable allied attachment work mode**
- **Selectable cushion attachment control**
- **Self-Diagnostic System**
- **Auto engine warm up**

Hose Burst Check Valves (HBCV) Optional

Integral Cylinder Cushion Design

- **Attachment**
New design heavy duty box section attachment with central lube bank.

- **Illuminated LCD Service Monitor**
Programmable in 14 languages.

- **Operator's Control Station**
Mounted on 6 fluid mountings with: heater, oscillating fan, seat belt, horn, dome light, AM/FM radio, digital clock, and 3 safety control lockouts including a gate lock safety shutoff.

- **Buckets**
Wide variety of quality Esco buckets with Super V tooth system.

Quantum

SERIES EXCAVATORS

- **Power Up Button**
9% power increase at the touch of a button.

- **One-Touch Decelerator or Auto Idling**
Operator has choice of one-touch decelerator or programmable auto idling.

- **Hand Grab Rails**
Standard on operator's cab and on top of both sides of machinery house.

- **Boom Holding Valves**

- **Nephron Oil Filtration System**
Cleans the hydraulic fluid of condensation and all contaminants over one micron in diameter.

- **Diesel Engines**
Turbocharged, reliable, fuel efficient, and quiet.

- **Swing-Out Oil Cooler**
Opens 60° for easy maintenance.
(Standard on 2800, 3400, 3900 & 4300)

- **Long Undercarriage**
LC undercarriage with heavy duty excavator style components.

- **Auxiliary Spool**
For allied attachments.

- **Track Frame**
Reduces soil buildup.

- **Alternating Inner/Outer Flanged Rollers**
Assures proper rail engagement; filled with synthetic oil.

- **Operator's Seat**
Reclining/sliding fully suspended seat for all day comfort.

- **Control Console**
4-position tilting/sliding.

- **Undercovers**
Fully covered upper and lower.

- **Superior Visibility**
Safety glass front window. LEXAN® MARGARD™ rear and side windows eliminate need for vandal covers.

- **Carbody**
X-style carbody for strength and durability.

- **Three Speed Travel**
Low, mid-range, and high speed controlled by foot switch.

- **Automatic downshift function**
Automatically shifts machine from high to mid-range speed when traveling on an incline for increased tractive effort.

- **Single pedal travel** Standard on 3400, 3900, 4300 and 5800.

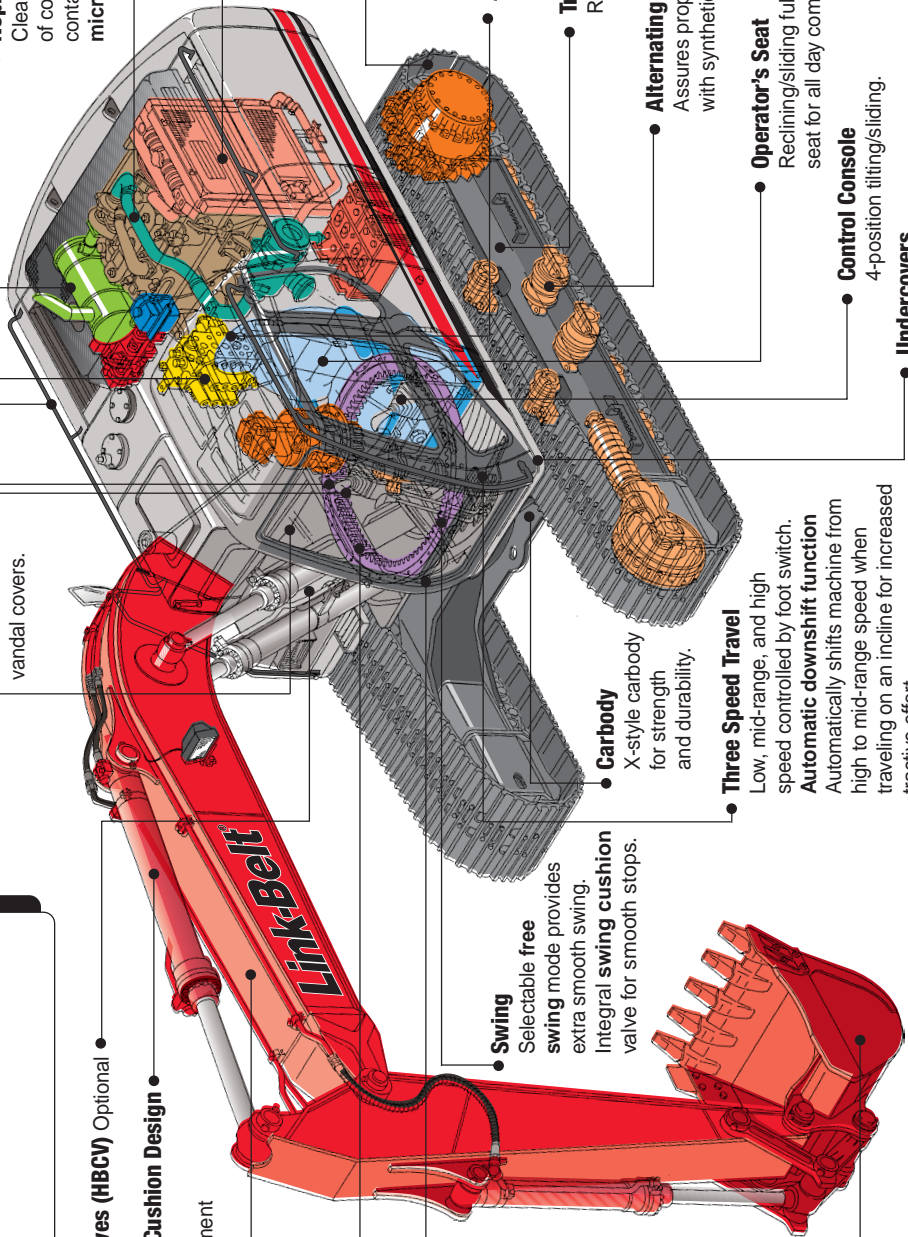

Quantum Added Value Features



Operator's Control Station Offers superior visibility and more! The operator's control station is designed with the operator in mind, and is mounted to the frame on six fluid filled mountings for minimal vibration. Features include a wide opening door, a cloth upholstered suspension seat with integral headrest and armrests, heater with 3-speed fan, AM/FM radio, cigarette lighter, pop-up skylight window, oscillating fan, and intermittent windshield wiper with washer.

Nephron Oil Filtration System

The Nephron filter eliminates contaminants of 1 micron or more in size. This significantly reduces hydraulic system breakdown and maintenance costs under normal usage. Less wear and tear on the hydraulic components means you get more years of reliable performance from your Quantum.



Long Carriage Undercarriage Long undercarriages incorporate heavy duty excavator style components. X-style carbody is integrally welded for maximum strength and durability. Newly designed side frames incorporate a peaked saddle shape and large cut-outs on top for reduced dirt build-up. Track adjustment is made easy with standard grease cylinder track adjusters and shock absorbing springs.



Bearing "Tub" Built into the "X" style carbody is the turntable bearing "tub" which extends down through the top plate and is welded to the bottom of the carbody as well as the top for increased strength.

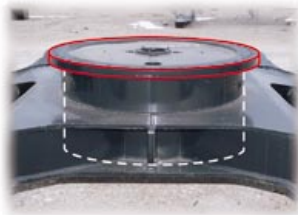

Swing Out Oil Cooler

A swing out oil cooler assembly is standard on the 2800, 3400, 3900 and 4300. Compared to competition, this unit provides exceptional wide opening access (60°) for easy, thorough cleaning. A removable dust protection screen situated in front of the oil cooler protects the cores from large particles of dust.



Serviceability Servicing the Quantum excavator is simplified by the use of large, wide opening doors. Standard quick disconnects for pressure checking and central lube banks for attachment pins also provide quick routine maintenance. A grease gun and tool kit are provided as standard service equipment.



Product Support With Link-Belt, your excavation investment is always protected. With a coast-to-coast distributor network, you're never far from Link-Belt.

Illuminated LCD Service Monitor Easy to read illuminated monitor can display up to 19 messages including work modes, power up, free swing, engine idling, auto warm up, engine preheat ... and several other audio visual caution and warning messages which keep the operator in touch with critical machine functions. A bar graph display section constantly monitors the water temperature, hydraulic oil temperature and fuel level. Also continuously displayed on the monitor are selected travel speed, swing lock on/off, working mode and a digital clock.



Free Swing Control The standard free swing feature allows the operator to disengage the swing brake providing precise control and smooth stops when swinging a load. The swing brake can be engaged to eliminate the upper from coasting when working on a hillside.



Cushioned Attachment Control Push-button cushioned attachment control can be selected for the boom and arm hydraulic circuits which incorporate a cushion valve to further reduce shock and vibration.



Power Up Mode A button on the right controller lets the operator apply more power instantly. A touch of the button gives the system a 9% power boost for 8 seconds...ideal for powering through those tough rocks and stumps or lifting a heavier load.

One Touch Decelerator The operator can also control engine idling by using the one-touch decelerator located on top of the right control lever. The operator can push this button to bring the engine speed down to idle while waiting for trucks, etc. Another touch of the button brings the engine rpm back to the original throttle setting.