

350X₂

specifications

Operating Weight: 79,146 lbs. (35 900 kg)

SAE Net Horsepower: 271 HP (202 kW)

Bucket Range: 1.08 - 2.93 yd³ (.83 - 2.24 m³)

Engine

Isuzu AH-6HK1XYSS Tier 3 turbocharged diesel engine with electronic fuel control, 6-cylinder, water-cooled, EGR with cooler, air-to-air intercooler, fuel cooler, auto idle start, neutral safety start, glow plugs, auto warm-up, EPF engine protection, dual stage fuel filtration, remote oil filter, green plug oil drain.

SAE net horsepower 271 HP (202 kW) @ 2,000 rpm
 Displacement 7.8 L
 Maximum torque 797 lbf-ft (1 080 N-m) @ 1,500 rpm
 Starter 24V-5.0kW
 Alternator 50 amp
 Battery 128 amp hours

Cab and Controls

Pressurized cab with climate control a/c and heat with defroster, LCD monitor, illuminated soft-touch switches, low-effort controls pre-wired for auxiliary hydraulics, control pattern changer, single pedal travel, sliding LEXAN® MARGARD® windows, safety glass front window with automatic locking system and vandal cover, intermittent windshield wiper with washer, emergency rear window exit, polycarbonate roof hatch with sunshade, shockless cab suspension with four fluid mountings, KAB® reclining suspension seat, sliding 4-position tilting control consoles, AM/FM radio, digital clock, dome light, seat belt, coat hook, cup holder, storage compartments, floor mat, footrests, ashtray, 24-volt cigarette lighter, 12-volt outlet, travel alarm, handrail, mirrors.

Four selectable working modes, anti-theft password protection system, on-board self-diagnostic system with memory, auto-idling system, one-touch decelerator, auto power boost, gate lock safety shutoff.

A/C output 18,100 BTU/hr
 Heater output 20,150 BTU/hr
 Sound level (inside cab) 70.7 dB(A)
 Sound level (exterior) 102.9 dB(A)

Hydraulic System

Open-center system, two variable displacement axial piston pumps and one gear pump for pilot controls, main control valve with one 4-spool valve and one 5-spool valve with auxiliary spool - stackable, oil cooler, auto power boost, boom and arm holding valves, o-ring face seals, 6 micron return filter, firewall.

Hydraulic Pumps
 Maximum flow 2 x 76.6 gpm (2 x 290 l/min)
 Pilot pump maximum flow 7.9 gpm (30 l/min)

Relief Valve Settings
 Boom/arm/bucket 4,970 psi (343 bar)
 in Power-Boost Mode 5,410 psi (373 bar)
 Swing circuit 4,410 psi (304 bar)
 Travel 4,970 psi (343 bar)

Hydraulic Cylinders
 number of cylinders – bore x rod x stroke
 Boom 2 – 5.7" x 3.9" x 58.9"
 (145 mm x 100 mm x 1 495 mm)
 Arm 1 – 6.7" x 4.7" x 68.8"
 (170 mm x 120 mm x 1 748 mm)
 Bucket 1 – 5.9" x 4.1" x 47.6"
 (150 mm x 105 mm x 1 210 mm)

Hydraulic Oil Filtration

Return filter 6 micron
 Pilot filter 8 micron
 Suction screen 105 micron



Swing

Planetary reduction powered by axial piston motor. Internal ring gear with grease cavity for swing pinion. Swing bearing is single-row shear type ball bearing. Mechanical disc swing brake. Auto power swing.

Swing speed 0 – 9.8 rpm
 Tail swing 11' 4" (3.45 m)
 Swing torque 82,607 lbf-ft. (112 kN•m)

Undercarriage

X Pattern carbody with 16' 4" (4.98 m) undercarriage by 8' 6" (2.6 m) track gauge, sealed and strutted track chain with track guide, sealed rollers and idlers, two-speed independent hydrostatic travel with compact planetary final drive, disc type brakes, adjustable track tension, swivel guard.

Carrier rollers 2 per side
 Track rollers 8 per side
 Track link pitch 8.50" (216 mm)
 Shoes 48 per side
 Shoe width 31.5" (800 mm)
 Ground pressure 7.25 psi (.50 bar)

Lubricant and Coolant Capacity

Fuel tank 153.22 gal. (580 liters)
 Hydraulic tank 46.23 gal. (175 liters)
 Hydraulic system 92.46 gal. (350 liters)
 Final drive (per side) 2.51 gal. (9.5 liters)
 Swing drive 2.09 gal. (7.9 liters)
 Engine oil 10.04 gal. (38.0 liters)
 Cooling system 7.93 gal. (30.0 liters)

Travel System

Two-speed independent hydrostatic travel with compact axial piston motors. Hydraulic motor powered output shaft coupled to a planetary reduction unit and track sprocket. All hydraulic components mounted within the width of side frame. Automatic downshift. Single pedal travel. Spring applied, hydraulically released disc parking brake built into each motor. Each travel motor equipped with counterbalance valve to prevent overspeeding down an incline.

Max. travel speed 2.2 - 3.4 mph (3.5 - 5.5 km/h)
 Drawbar pull 59,619 lbf (265 kN)
 Gradeability 70% (35°)

Attachment

Boom 21' 2" (6.45 m)
Available Arms Digging Force*
 • 10' 8" (3.25 m) 36,850 lbf (164 kN)
 with Auto Power-Boost applied 40,020 lbf (178 kN)
 • 8' 8" (2.63 m) 43,840 lbf (195 kN)
 with Auto Power-Boost applied 47,430 lbf (211 kN)
 • 13' 3" (4.04 m) 31,590 lbf (141 kN)
 with Auto Power-Boost applied 34,310 lbf (153 kN)
 Bucket Digging Force 51,440 lbf (229 kN)
 with Auto Power-Boost applied 55,840 lbf (248 kN)

*Digging force ratings are based on ISO 6015, "Earthmoving Machinery – Hydraulic Excavators – Tool Forces."

Fuel Usage*

Heavy 10.6 gal / hr (40.1 liter / hr)
 Average 8.5 gal / hr (32.2 liter / hr)
 Light 5.3 gal / hr (20.0 liter / hr)

*Fuel economy varies widely depending on application. "Heavy" represents nearly continuous operation in tough digging applications in SP Mode. "Light" represents easy digging applications utilizing the machine about 50% of the time in SP Mode.

Operating Weight

Working weight with 31.5" (800 mm) shoes, 21' 2" (6.45 m) boom, 10' 8" (3.25 m) arm 2,580 lb. (1 170 kg) bucket, 16,314 lb. (7,400 kg) counterweight
 79,146 lbs (35,900 kg)

350 X2 Specifications

Working Ranges

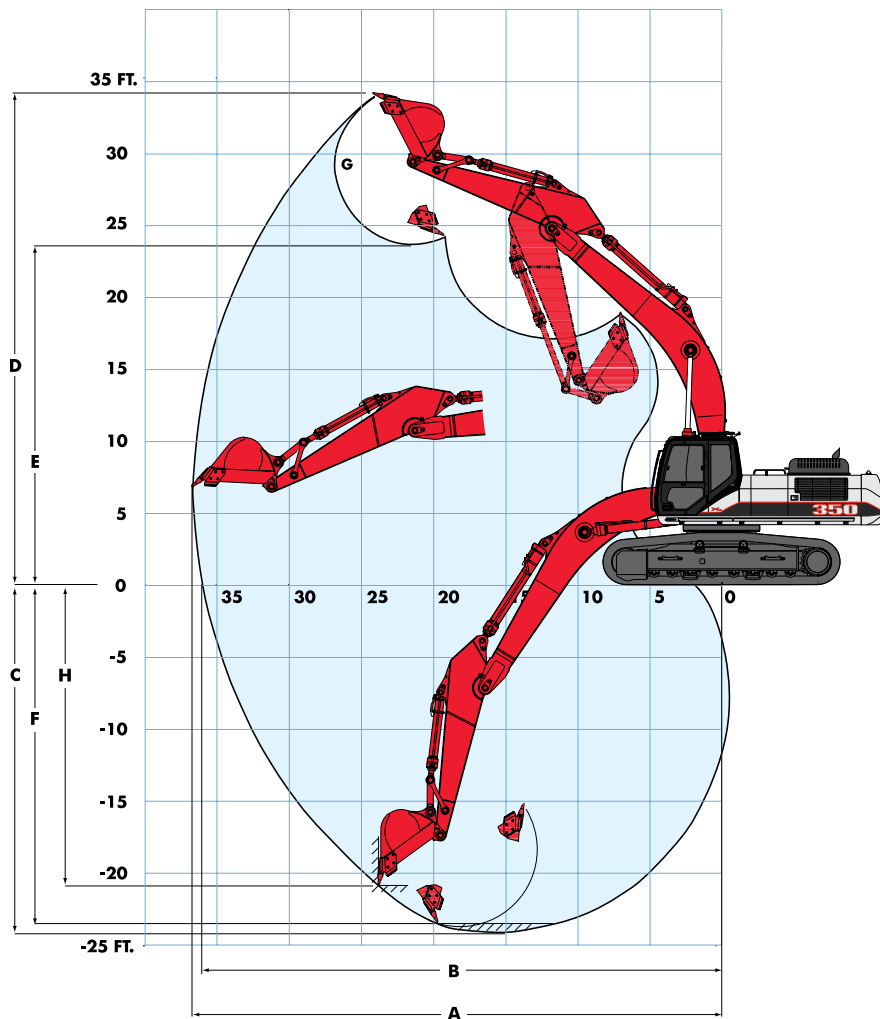

Machine equipped with 21' 2" (6.45 m) boom	10' 8" Arm (3.25 m)	8' 8" Arm (2.63 m)	13' 3" Arm (4.04 m)
A. Maximum reach	36' 8" (11.17 m)	35' 0" (10.67 m)	39' 1" (11.90 m)
B. Maximum reach @ ground level	36' 0" (10.98 m)	34' 4" (10.47 m)	38' 5" (11.72 m)
C. Maximum dig depth	24' 1" (7.34 m)	22' 1" (6.73 m)	26' 8" (8.14 m)
D. Maximum dig height	34' 0" (10.37 m)	33' 10" (10.32 m)	35' 0" (10.67 m)
E. Maximum dump height	23' 9" (7.23 m)	23' 5" (7.14 m)	24' 9" (7.54 m)
F. Digging depth - 8' (2.44 m) level bottom	23' 7" (7.19 m)	21' 6" (6.55 m)	26' 3" (8.01 m)
G. Bucket rotation	173°	173°	173°
H. Maximum vertical wall depth	20' 10" (6.35 m)	19' 7" (5.97 m)	23' 5" (7.15 m)

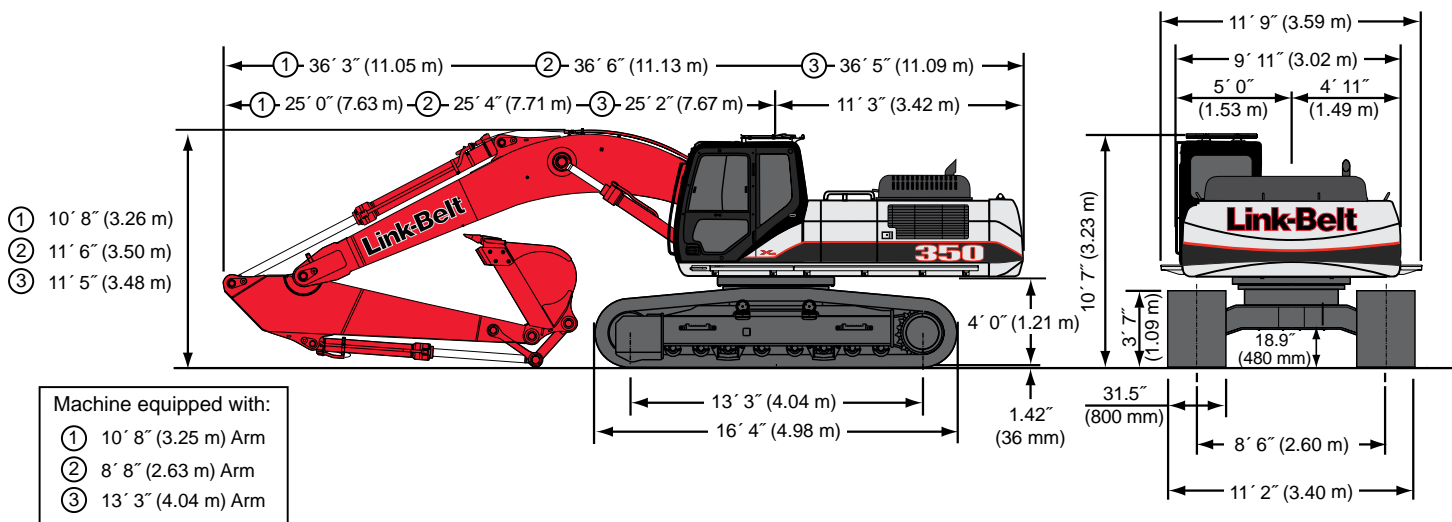

350 X2 Specifications

Bucket Sizes

Bucket Type	SAE Heaped Capacity		Width Outside Lip		Bucket Weight		Number of Teeth	Arm Length		
	(yd³)	(m³)	(in)	(mm)	(lbs)	(kg)		8'-8" 2.63 m	10'-8" 3.25 m	13'-3" 4.04 m
STDP	1.26	0.96	30	762	2306	1046	4	H	H	H
	1.59	1.22	36	914	2516	1141	4	H	H	H
	1.92	1.47	42	1067	2789	1265	5	H	H	M
	2.25	1.72	48	1219	2956	1341	5	H	M	L
	2.59	1.98	54	1372	3226	1463	6	M	M	L
	2.93	2.24	60	1524	3396	1540	6	L	L	N/A
HDP	1.22	0.93	30	762	2886	1309	4	H	H	H
	1.54	1.18	36	914	3131	1420	4	H	H	H
	1.86	1.42	42	1067	3459	1569	5	H	H	M
	2.19	1.67	48	1219	3704	1680	5	H	M	L
	2.53	1.93	54	1372	4031	1828	6	M	L	L
XDP	1.12	0.86	30	762	3327	1509	4	H	H	H
	1.42	1.09	36	914	3620	1642	4	H	H	H
	1.73	1.32	42	1067	3994	1812	5	H	H	M
	2.04	1.56	48	1219	4287	1945	5	H	M	L
POWER	1.08	0.83	30	762	3461	1570	4	H	H	H
	1.35	1.03	36	914	3688	1673	4	H	H	H
	1.62	1.24	42	1067	3860	1751	5	H	H	M
	1.90	1.45	48	1219	4030	1828	5	H	M	L
	2.18	1.67	54	1372	4257	1931	6	M	M	L
DITCH	2.20	1.68	72	1829	2971	1348	0	H	M	L

STDP - Standard duty plate
HDP - Heavy duty plate
XDP - Extreme duty plate
POWER - HDP for use with ESCO multi-pin grabber only

Approval Code For Arm/Bucket Combinations

H..... Heavy material (up to 3,370 lbs./yd³)
M..... Medium material (up to 2,700 lbs./yd³)
L..... Light material (up to 2,020 lbs./yd³)
N/A..... Not applicable

Standard Equipment

- KAB 815 sliding/reclining suspension seat with adjustable 4-inch armrests, lumbar support and retractable seat belt
- Safety glass front window with auto lock, windshield wiper and washer with intermittent speeds, Lexan® side and rear tinted windows
- 4-position tilting consoles with memory position and hydraulic lock-out
- Auto climate control a/c and heat
- AM/FM stereo with mute button, horn, interior light, digital clock, hour meter, floor mat, cup holder, sun shade, storage, LH and RH rear view mirrors
- Single pedal travel
- Travel alarm with cancel switch
- Vandal guarding with bolt-on FOG capability
- EPA Tier III Isuzu diesel engine
- Common rail fuel injection
- Turbocharger with intercooler
- Neutral safety start
- Idle start
- Glow plug pre-heat
- Auto engine warm-up
- Auto idling system
- One-touch idle
- Dual remote fuel filters with water separation
- Double element air filter with in-cab restriction indicator
- External fuel gauge
- Remote, full-flow engine oil filter
- Green plug engine oil drain
- EPF Engine Protection
- Emergency engine stop
- Open-center hydraulic system
- Four selectable work modes including attachment mode

- Auto power boost
- Auto swing priority
- Pre-set auxiliary pump settings - 10
- Auxiliary valve
- Stackable main control valve
- Auxiliary pipe brackets
- Control levers pre-wired for auxiliary
- Control pattern changer
- Sealed and lubricated track chain
- Two-speed with auto shift and straight travel
- Planetary drive
- Spring-applied, hydraulic release brake
- Hydraulic track adjust
- Swivel guard belly pan
- Track guides
- Vandal locks with common key
- 16,314 lb. (7,400 kg) counterweight with lifting eyes
- 21-ft 2-in (6.45 m) boom
- EMS (Extended Maintenance System) 1,000 hour service interval throughout entire attachment except bucket
- Attachment cushion valve
- Arm and boom speed assistance
- Arm and boom regeneration
- Arm and boom holding valves
- Cylinder cushion
- Centralized lube bank
- Bucket anti-clatter device
- Illuminated LCD service monitor
- On-board diagnostic system
- Anti-theft device
- 12-volt accessory outlet
- 70-watt work lights on boom and upper

Options

- Arms
 - 10-ft 8-in (3.25 m)
 - 8-ft 8-in (2.63 m)
 - 13-ft 3-in (4.04 m)
- Tracks
 - 31.5-in (800 mm) 3-bar grouser
 - 27.5-in (700 mm) 3-bar grouser
 - 33.5-in (850 mm) 3-bar grouser
- Hydraulics
 - Single-acting with switch or pedal activation
 - Multi-function with switch activation and in-cab flow direction control
 - Thumb hydraulics with switch activation
 - 2nd and 3rd auxiliary with switch and pedal activation
- Couplers
 - ESCO multi-pin grabber
 - Dromone automatic quick-coupler
- Thumbs
 - Universal rigid
 - Hydraulic non-link
 - Hydraulic non-link for coupler
 - Hydraulic link
 - Hydraulic link for coupler
- Cab lights - exterior
- Air-suspension seat
- Free Swing
- Cyclone pre-clean air filter
- FOG guard
- Front guard - mesh or bars
- Attachment reinforcement plating
- HD bucket linkage
- Track guides - triple
- Catwalks

Notes: Excavator lifting capacities

1. Lifting capacities shown should not be exceeded. Weight of all lifting accessories must be deducted from the above lifting capacities.
2. Lifting capacities are based on machine standing on firm, uniform supporting surface. User must make allowances for job conditions such as soft or uneven ground.
3. Lifting capacities shown do not exceed 75% of minimum tipping loads or 87% of hydraulic capacities. Capacities marked with an asterisk (*) are limited by hydraulic capacities.
4. Least stable position is over the side.
5. Operator should be fully acquainted with the Operator's Manual & Operating Safety Booklet, furnished by LBX before operating the machine.
6. Capacities apply only to the machine as originally manufactured and normally equipped by LBX Company LLC.
7. Lift capacity ratings are based on SAE J1097, "Earthmoving Machinery - Hydraulic Excavators - Lift Capacity."



LBX Company is the proud maker of quality Link-Belt excavators and is located in Lexington, KY.



Litho in USA 12/10 #LBX2177 (supersedes #LBX2168)

© LBX and © Link-Belt are registered trademarks. Copyright 2010. All rights reserved. We are constantly improving our products and therefore reserve the right to change designs and specifications.